

# HRP-POA 45G

**Levelling castor, with integrated truck lock and top plate fitting, nylon wheel**

**EAN** 4047526117566  
**ID** 757018  
**Customs tariff number** 83022000

**Bracket:** HRP series

- die-cast aluminium, powder-coated, colour ivory
- sealed ball bearing in the swivel head
- steel top plate
- truck lock made of hard rubber
- height adjustment using wrench or integrated adjustment wheel
- steel parts zinc-plated, blue-passivated, Cr6-free

**Wheel:** POA series

- high-quality nylon 6, impact resistant, hardness 70 Shore D, colour black

**Other features:**

- Load capacity determined under the following conditions:
  - speed: max. 1 km/h
  - temperature: +15 °C to +30 °C
  - hardness, horizontal tread without obstacles
  - route: A cooling off period of 15 minutes is required after a maximum of 50 m



**Tread and tyre hardness**

■■■■■ 70 Shore D

**Rolling resistance**

■■■■■ excellent

**Wear resistance**

■■■■□□ good

**Operating noise / floor surface preservation**

■■■■□□ satisfactory

**Technical data:**

Wheel Ø (D)	⌀	45 mm
Wheel width	∅	18 mm
Load capacity at 1 km/h	⊞	180 kg
Bearing type	⊙	plain bore
Total height (H)	∅	72 mm
Max. total height (h)	∅	79 mm
Adjustment range (T4)	↔	7 mm
Max foot floor clearance (T3)		8 mm
Plate size	□	55 x 55 mm
Bolt hole spacing	⊞	42 x 42 mm
Bolt hole Ø	⌀	7 mm
Offset (F)	⊞	32 mm
Temperature resistance min		-25 °C
Temperature resistance max		80 °C
Tread and tyre hardness		70 Shore D
Unit weight	⊞	0.4 kg
Non-marking		✓
Electrically conductive	⊞	✗
Antistatic	⊞	✗
Corrosion-resistant		✗
Heat-resistant	⊞	✗

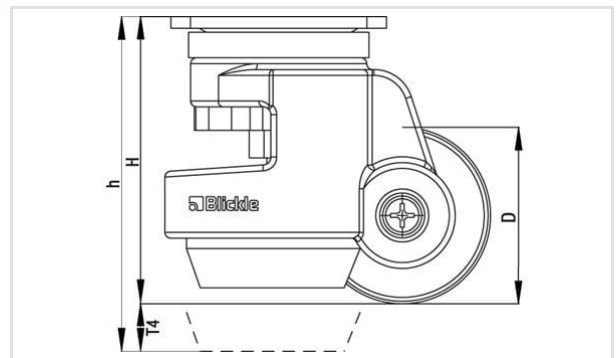

Non-staining	✓
Tread hydrolysis-resistant	✗
Suitable for autoclaves	✗
Suitable for machine washing	✗