

# LKDG-PATH 100K-FI

**Blickle synthetic twin castor MOVE, colour silver grey, with brake system 'stop-fix', wheel, with thermoplastic polyurethane tread, with nylon wheel centre**

**EAN** 4047526355661  
**ID** 935721  
**Customs tariff number** 87169090



**Bracket:** LKDG series

- high-quality nylon 6, impact resistant
- two grooved ball bearings in the swivel head sealed on both sides
- bolt hole
- colour silver grey RAL 7001
- modern, appealing design

**Wheel:** PATH series

- tread: high-quality thermoplastic polyurethane (TPU), hardness 94 Shore A, colour dark grey, non-marking, non-staining
- wheel centre: high-quality nylon 6, impact resistant, colour silver grey RAL 7001

**Other features:**

- very high chemical resistance to many aggressive substances
- operating temperature: -20 °C to +60 °C, temporarily up to +80 °C, reduced load capacity over +30 °C
- Swivel castor with "stop-fix" brake with easy release kick lever as standard

**Technical data:**

Wheel Ø (D)	⊘	100 mm
Wheel width	⊥	18 mm
Number of wheels		2
Total castor width	⊘	71 mm
Load capacity at 3 km/h	⊞	100 kg
Load capacity (static)	⊞	250 kg
Bearing type	⊙	ball bearing
Total height (H)	⊘	103 mm
Plate Ø	⊘	42 mm
Bolt hole	⊙	13 mm
Offset (F)	⊞	31 mm
Temperature resistance min		-20 °C
Temperature resistance max		60 °C
Tread and tyre hardness		94 Shore A



**Tread and tyre hardness**  
 ■■■■■□ 94 Shore A

**Rolling resistance**  
 ■■■■■□ very good

**Wear resistance**  
 ■■■■■□ good

**Operating noise / floor surface preservation**  
 ■■■■■□ good

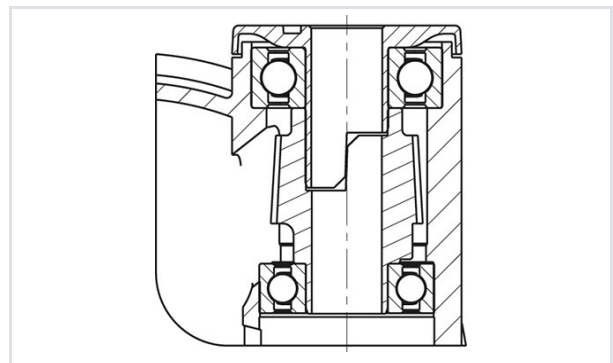

Unit weight	0.5 kg
Non-marking	✓
Electrically conductive	✗
Antistatic	✗
Corrosion-resistant	✗
Heat-resistant	✗
Non-staining	✓
Tread hydrolysis-resistant	✗
Suitable for autoclaves	✗
Suitable for machine washing	✗

